

32-Channel Ultrasound Analog Front-End Receiver Modules

General Description

The Simplify SMM9132 and SMM9133 are complete 32-channel ultrasound receivers in a compact, easy to integrate SO-DIMM form-factor module. The module interfaces to 32 single ended analog inputs and delivers 32 lanes of high-speed serialized LVDS on its outputs.

These modules combine all of the complexity of the analog front-end including T/R switch, LNA/VGA, and ADC onto a small 204 SO-DIMM form-factor. These modules utilize high-reliability PC-industry standard SO-DIMM connectors, in either a vertical mount configuration for high channel density applications, or a flat-mount for hand-carried or handheld applications. The module is fully-tested to meet all analog performance specifications for B-mode, harmonic imaging, and PW Doppler, with up to 8 dB higher performance than competing solutions, while still consuming only 100mW per channel. This modular design is available in both CW Doppler and non-CW options simplifying inventory management for the manufacturer. All devices on the module are managed through a single SPI interface.

The SMM9132/SMM9133 are designed around Simplify's SAM1600 - the industry's highest density, lowest power 12-bit, 65Msps ADC, coupled with the MAX2077/8 octal amplifier front-end.

SMM9132 delivers an ultra-low full channel noise figure of 2.4dB (at $R_s=R_{in}=200\Omega$) as well as a low output-referred noise of 43.7nV/rtHz (at 5MHz, 20dB gain) for a high broadband SNR of over 68dB. The combination of low noise figure and high SNR provide excellent B-mode and 2nd harmonic imaging performance, while a very high near-carrier measured SNR of 139.7dBc/Hz at a 1kHz offset from a 3.5MHz carrier provides optimal PW and color-flow Doppler sensitivity. The SMM9133 - designed for CW Doppler mode - integrates a mixer-based beamformer with near-carrier SNR of 154dBc/Hz at 1kHz offset from a 1.25MHz, 200mVpp input clutter signal.

Complete 64-ch receiver carrier-board designs using two SMM913x modules are available from Simplify as a reference to jumpstart the user's design.



SMM9132/SMM9133 Module (1:1 scale)

Key Features

- 32 Complete receive channels including: T/R switch, LNA, VGA, AAF, and ADC
- 46mm x 67.6mm, 204-pin SO-DIMM form factor
- Up to 65Msps, 12-bit resolution using SAM1600 ADC
- **High-performance receiver**
 - SNR greater than 67dB at min-mid channel gain
 - HD2 at low-gain of -55dBc, better than -70dBc at high gain
 - IM3 distortion at low-gain of -60dBc, better than -75dBc at mid-high gain
 - Crosstalk better than -50dBFS
 - Overload Recovery in less than 1 cycle
- Single 3.3V SPI interface to control entire module
- High-speed 800Mbps LVDS outputs
- **Industry's lower power consumption** of 100mW/ch for the receiver signal chain

Simplified Block Diagram

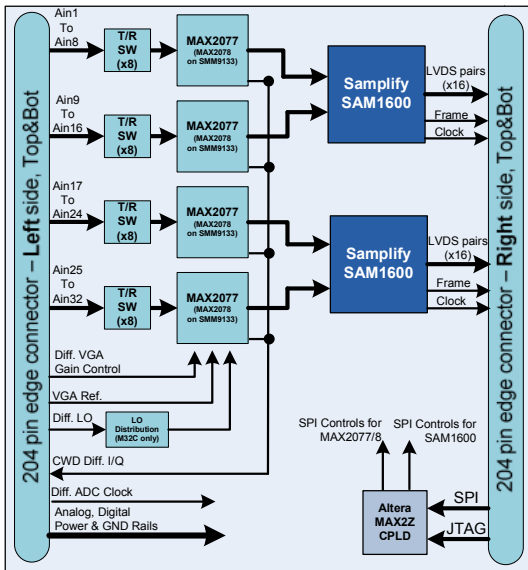

Figure 1: SMM9132/SMM9133 Block Diagram

Easy Integration and Modularity

The SMM9132 and SMM9133 modules are fully tested, 32-channel ultrasound receivers based on Simplify's proven ultrasound AFE receiver reference design. Interfacing to the modules for configuration and TGC control is accomplished using a single SPI interface to an on-module ultra-low-power CPLD that controls the 6 IC's and handles the voltage level translation. Thus, these modules appear to the system designer as a single 32-channel device which is 4x the density of competing octal devices.

These modules are implemented in the industry's highest density for factor. The modules can be mounted in horizontal and vertical configurations to accommodate various form-factor ultrasound machines including small hand-carried and hand-held ultrasound machines:

- 46mm x 67.6mm in flat-mount configuration
- <10mm x 67.6mm in vertical configuration

The modularity provided by the modules enables building-to-order for CWD and non-CWD systems thus simplifying finished goods inventory management.

Product Configurations

The receiver module is available in 2 configurations:

SMM9132 - Complete 32-channel receiver with no CW Doppler support

SMM9133 - Complete 32-channel as in SMM9132 plus fully integrated analog beamformer for CW Doppler. The module includes the MAX2078 instead of the MAX2077, LO clock distribution, and differential I/Q current-summed outputs.

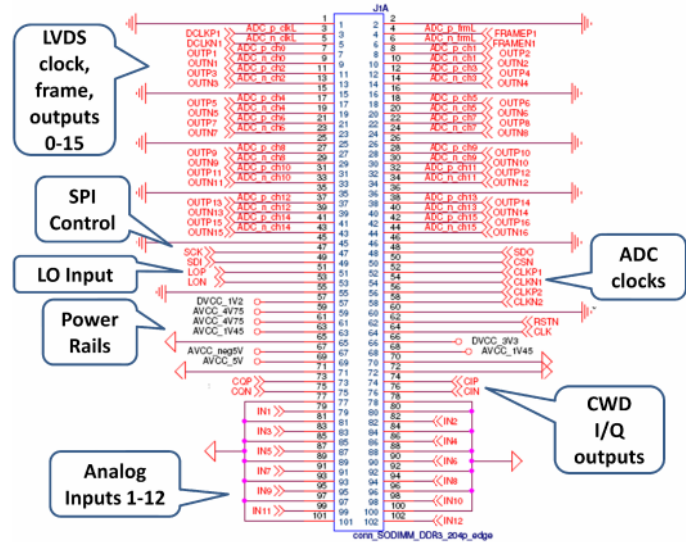

Figure 2: Left Half, Top and Bottom Pin-out

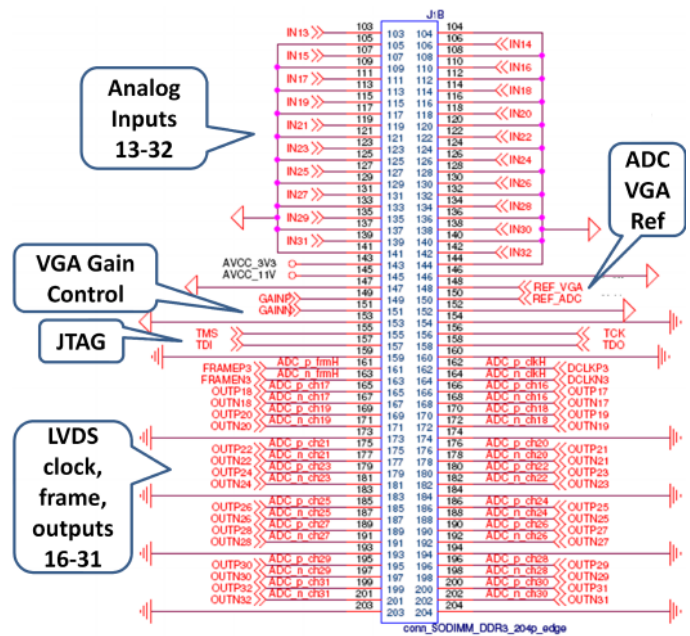

Figure 3: Right Half, Top and Bottom Pin-out

Cost Effectiveness

These modules are highly cost effective when considering the total lifecycle costs. R&D, manufacturing test, and inventory holding costs along with time to market can be greatly reduced when using the SMM9132/3 modules compared to designing at the chipset level.

Contact Information

Simplify Systems, Inc.
160 Saratoga Ave Suite 150
Santa Clara, CA 95051 USA
+1 (888) LESS-BITS
sales@samplify.com

WWW.SAMPLIFY.COM