

8/16-Channel, 65 Msps, 12 bit Low Power Compressing/Concentrating ADC

Description

The SAM1610 and SAM1600 combine 16 ADCs each operating at up to 65 MSPS with Simplify's patented Prism™ compression (SAM1610) and port concentration technology to reduce I/O bandwidth and complexity. The products are optimized to improve channel density, lower power, and reduce interconnection costs in medical imaging and wireless infrastructure applications. The SAM1605 combines 8 ADC channels with Simplify's Prism™ compression, making it ideal for direct conversion wireless applications.

Like legacy ADCs, the SAM1600 family provides one serialized LVDS output as speeds up to 800 Mb/s for each ADC channel, facilitating integration into legacy systems as an ADC only. However, the SAM1600 family reduces the number of LVDS pairs by using Simplify's patented Port Concentration and Prism™ compression technology, saving power and backplane or fiber optic transport costs.

At less than 50 mW/channel, the SAM1600 family is nearly half the power of existing ADCs extending battery life for portable applications, and reducing operating costs for wireless applications.

The SAM1600 Family of *Intelligent ADC's* received top honors from industry leading publications EDN and EP.



Key Benefits

- Highest density ADC: 16 channels in 12x12 mm BGA
 - 12 bit resolution, 40/50/65 MSPS
 - SNR = 68.5 dB
- Integrated Simplify Prism™ Compression for reduced I/O
 - Veribit™ lossless, Optibit™ & RateTrak™ near lossless modes
 - Low latency with packet sizes as low as 96 samples
- Integrated Simplify Prism™ Compression for reduced I/O
 - Veribit™ lossless, Optibit™ & RateTrak™ near lossless modes
 - Low latency with packet sizes as low as 96 samples
- 800 Mb/s serial LVDS outputs (ANSI-644, IEEE 1596.3)
- Port Concentration reduces LVDS pairs
 - 25% reduction in LVDS pairs at 50 Msample/s
 - 66% reduction in LVDS pairs with 3:1 compression
- Low power, < 50mW/channel

Applications

Ultrasound, SONAR and Medical Imaging
 LTE and WiMAX Infrastructure
 Automated Test Equipment

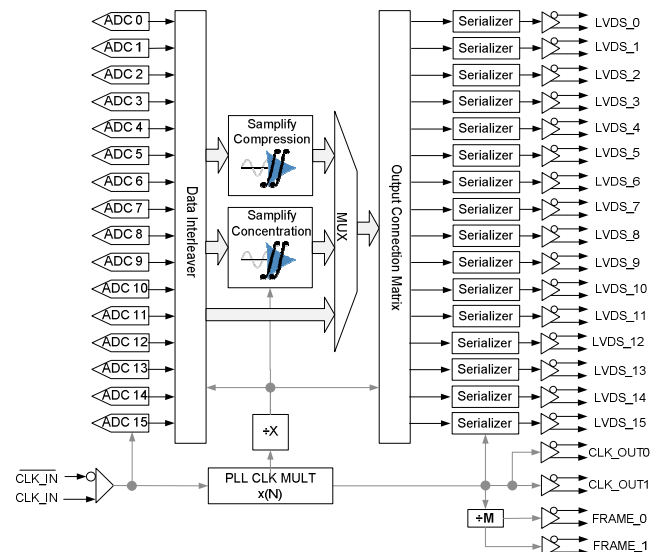

Product Specifications

Unless otherwise noted, the specifications in the following tables are measured under the following conditions: AVDD = 1.45 V ± 5%, DVDD = 1.2 V ± 10%, $f_{ADC} = 50$ MHz, $F_{in} = 1$ MHz, $A_{in} = -0.5$ dBFS. Typical values are at +25°C, min/max values are over full temperature range.

Power Supply

Parameter	Min	Typ	Max	Units
Analog Power Supply	1.38	1.45	1.52	V
Digital Power Supply	1.08	1.20	1.32	V
Total Power Dissipation		800		mW

ADC Specifications

Parameter	$f_{ADC} = 50$ MHz			Units
	Min	Typ	Max	
Resolution	12			Bits
No Missing Codes	Guaranteed			
Differential Non-Linearity (DNL)	± 0.9			LSB
Integral Non-Linearity (INL)	± 1.0			LSB
Differential Input Voltage Range	1.4			V _{diff,pp}
Common Mode Voltage	0.7			V
Over-range recovery time	2			samp
Signal to Noise Ratio	68.5			dBFS
Signal to Noise & Distortion Ratio	67			dBc
Effective Number of Bits	10.8			Bits
Spurious Free Dynamic Range	-73			dBc
Second Harmonic Distortion	-80			dBc
Third Harmonic Distortion	-73			dBc
Two Tone (IM3) AIN1 10MHz @ -0.5dBFS AIN2 10.1MHz @ -20.5 dBFS	-75			dBFS
Crosstalk	-75			dBFS

Compression Specifications

Parameter	Value	Units
Port Concentration Modes	4:3, 2:1, 8:3, 4:1	
Compression Modes	Veribit™ lossless Optibit™ fixed quality RateTrak™ fixed rate	
Compressed Packet Sizes	96/144/192	Samples
Compression Latency	1.48 max	µs
Optibit™ Mode Dynamic Range Resolution	0.5	dB
RateTrak™ Mode Compression Ratio Resolution	0.05	

Timing Specifications

Parameter	Value	Units
Maximum clock rate	65	MHz
Minimum clock rate	10	MHz

Typical Performance Characteristics

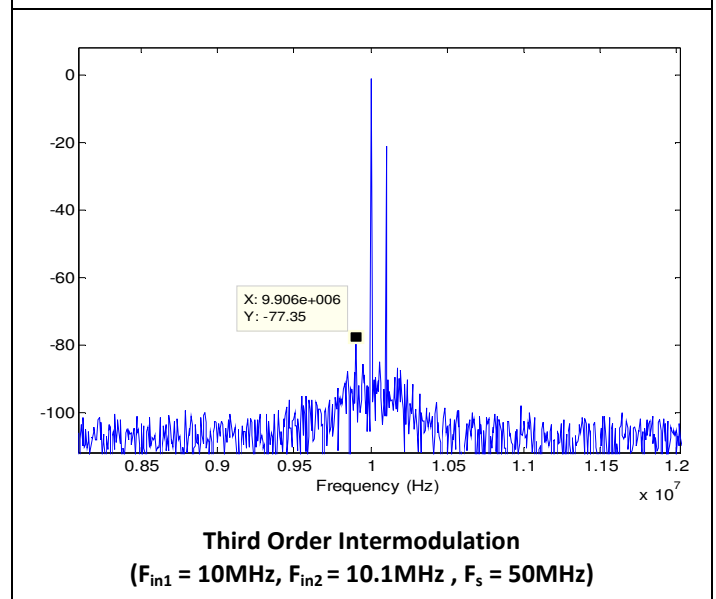
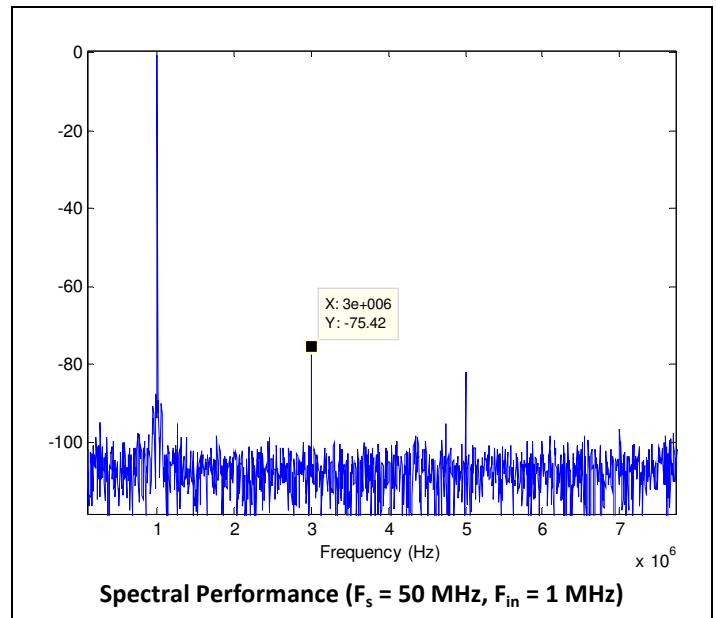

Ordering Information

Feature	SAM1610	SAM1605	SAM1600
Number of Analog Channels	16	8	16
Sample Rates	41/65	41/65	65
Prism™ Compression Mode	✓	✓	
Port Concentration	✓	✓	✓

Contact Information:

Samplify Systems, Inc.
160 Saratoga Ave Suite 150
Santa Clara, CA 95051 USA
+1 (888) LESS-BITS
sales@samplify.com