

64-channel AutoFocus™ Beamforming Platform and Development Kit

General Description

The Simplify SMK9130 is a complete 64-channel ultrasound front-end development kit using Simplify's SAM2032 AutoFocus™ beamformer ASICs. The SMK9130 provides the entire ultrasound front-end electronics from the probe interface on one side to the PCIe and USB 2.0 interface to the back-end CPU.

The heart of the SMK9130 is Simplify's AutoFocus receive beamformer ASIC – the SAM2032 - which is a high-performance, low-power device supporting dynamic focusing, dynamic apodization, and parallel beamforming for superior image quality and frame-rates. The SMK9130 supports all common ultrasound imaging modes including B-mode, CFM, PDI, PWD, and CWD.

The SMK9130 enables designers to develop and test their system software early, prior to HW development, thus greatly accelerating time to market. Ultrasound OEMs have two paths to production when developing with the SMK9130:

1. Focusing on time-to-market and using the SMK9130 system as-is in production of their end product
2. Use the system as a reference design when redesigning the boards based on OEM optimization for production (e.g. for channel configuration, form factor, cost, etc.). All the major components of the SMK9130 such as AFE and power modules, beamformers, are sold separately as components and used on these OEM-designed boards. With this option, the SMK9130 is used as a "golden" reference hardware platform for development and software integration.

In both cases, all software investments are protected using Simplify's ultrasound API (SUAPI). This high-level API provided with the system as a shared library and header files allows designers to control and configure all the many system parameters in terms of scan/frame/beam/firings/etc. definitions instead of low-level register access. The various data formats the system can output are easily defined with the API. Windows, Linux, and Mac OS are supported.

The SMK9130 is a unique system as it is the only commercially available complete ultrasound front-end electronics sub-system provided as an open software platform. Specialty OEMs who do not want to develop this complicated hard-to-design sub-sysm on their own can easily adapt it to their applications. Simplify or its partners can also modify any hardware component to create a semi or full custom hardware solutions on an NRE-basis. Academic, and other research institutions can use the system's flexibility and

configurability when exploring new algorithms or transducer technologies.

Key Features

Complete 64 channel Tx/Rx beamforming ultrasound front-end development system

Receive:

- Simplify AutoFocus™ receive beamforming using its high-performance, low-power SAM2032
- Two high-performance, low-power SMM913x complete 32-ch receiver modules
- 50Msps, 12-bit resolution AFE and receive beamformer
- Mid-processor functions in hardware supporting color Doppler imaging modes including CFM, PDI, PWD, CWD
- Full CW Doppler mode hardware support in receive signal chain

Transmit:

- Simplify's SFF9140 fully programmable Tx beamformer
- 3 or 5-level transmit pulsers (+/-100V, GND)

Power:

- Low-noise, fast switching high-voltage power supply module and control
- Power supervisor automatically shuts off high-voltage rails if system becomes unstable
- Medical class2 15V/60W AC/DC power supply (included)

Software:

- Simplify ultrasound API (SUAPI)
- Windows XP/7, Linux, Mac OS supported
- Demo back-end imaging software from Simplify partners
- PCI-express and USB host interface support

Entire system fully enclosed in metal chassis
Expandable system to support 256 channels



Figure 1: SMK9130 with Probe Connected

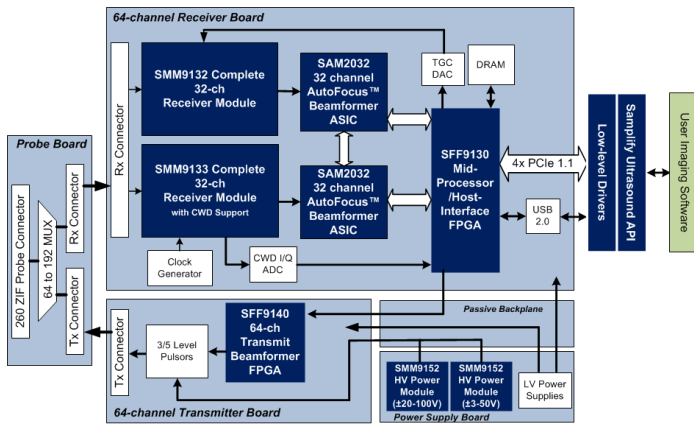

Figure 2: SMK9130 High-Level Block Diagram

Note: blocks in dark blue are components or IP sold or licensed for production in customer designed boards based on the SMK9130

What's Included and Pricing

The system consists of 5 boards (Receive, Transmit, Power Supply, Probe Interface, and Backplane) and 2 receiver modules all assembled in a chassis, bit files for the two FPGAs in the system, a 15V/60W medical class 2 AC/DC power supply, Simplify's ultrasound API, low-level drivers, demo back-end imaging source code, 3 months support included with further support based on quarterly fee. The price of the system is US\$60,000 and also includes a license to use the designs (schematics and layout) as a reference for customer's own boards for production. Other pricing options are available for those who do not need a production license such as those using the system as-is in production or universities and other academic research institutions.

Related Products

Although the SMK9130 is a complete ultrasound front-end production ready system, when used as a reference design, the same major components (shown in dark blue in Figure 2) are used and are available from Simplify. These are all available from Simplify in production volumes and are described on www.simplify.com/ultrasound.

SMK9130 Specifications

General

- Over 1000 parameters programmable by user with included software API
- 64 ADC channels multiplexed by up to 3:1 to support 192 elements
- Many application presets available
- 22 seconds start-up time

Imaging

- Mid-processor support for B-mode, PDI, CFM, PWD, CWD
- Frame rates of up to 28 fps over USB2.0 interface
- Resolution: lateral 0.5mm, axial 0.5mm
- Geometrical precision: 0.1mm or 1 pixel
- Blind area: 1mm on top
- 256 grayscale levels in B-mode
- Multi frequency scan
- Multi zone focus
- Scan angle from 0 deg to 150 deg
- Image depth: 1mm to 40cm

Simplify Ultrasound API (SUAPI) & FrameViewer Imaging SW

- SUAPI: high-level middleware SW layer providing full control over HW:
 - All Rx/Tx beamforming, mid-processing, AFE, power, etc. settings programmable
- Real-time basic imaging software with no post-processing
- C++ source code provided for FrameViewer and other examples
- Windows/Linux/macOS support; Intel x86 or ARM CPUs
- Image size: width 10..2000 pixels, height: 10..2000 pixels

- Image left-right, up-down, and black-white reversing, pseudo colors
- 10 TGC sliders for any depth; 90dB dynamic range
- Real-time depth adjustable in B-mode
- Lossless digital storage of still image
- Over 30 parameters controlled via GUI

Receive

- 1-beam; 2-beams; 4-beams parallel processing
- Continuous receive focus: coefficients updated on every sample
- Apodization with 8 windows, $F\# = 1/16..16$
- Dynamic Range: input 12bit (ADC), 132dB front end
- 512 beams predefined maximum in memory
- TGC in 32 zones programmable, interpolated; 90dB range
- TFC in 32 zones programmable; 162dB dynamic range
- Linearity: ± 1 dB in any 60dB interval
- Frequency range: 1MHz to 18MHz
- Input Noise: $2.4nV / \sqrt{\text{Hz}}$
- Sampling rate: 10MHz to 50MHz
- Maximum delay 2048 samples at sampling clock
- VGA gain slope maximum 32dB / 20us; 12bit resolution
- Close-in phase-noise (at 1KHz offset from 3.5MHz carrier): -140dBc/Hz

Transmit

- 256 pulse shape tables; 252 pulses at 200MHz
- Output pulse rate: 500KHz to 100MHz
- Repetition counter 1..64000 or continuous (CWD)
- Pulse duty cycle adjustment to 5ns precision
- Apodization $F\#$: 1/16..16
- Up to 512 beams stored in memory
- Maximum delay of 2048 samples at system clock
- Delay resolution: 5ns
- Rise time: 2-7ns (probe inductance dependent)
- 3-level or 5-level pulser configurations available
- Reference frequency: 40MHz ($\pm 5\%$) or 56MHz ($\pm 5\%$)
- Jitter 1σ (at 5MHz): 25ps
- Phase Noise (at 5MHz, 1KHz offset): -116 dBc/Hz

High-voltage Power Supplies

- High-voltage power supplies- A: 40V to 190V; B: 6V to 50V
- Current: 2Amp/ch (132A total during rise time)
- Voltage rise time (zero to maximum): 400-600ms
- 16-bit programming for min to max voltage range

Clocking

- System clock = Sampling clock range 10MHz to 65MHz
- Software programmable division of 840MHz internal clock by 13..32 and 56MHz internal clock by 1..32 to generate other clocks
- Hardware provides external clock input from 10MHz to 65MHz

Interfaces

- Host interfaces: USB2.0, PCI-Express 1.1 x4
- Extern clock input (SMA): 10MHz to 60MHz / 3.3V / single ended
- Extern clock output (SMA): 10MHz to 60MHz / 3.3V / single ended
- Beam start output (DIL): 3.3V / single ended / 50ohm
- Trigger output (DIL): start output ± 1000 samp/3.3V/single ended/50ohm
- User SPI Port: 2.5V / 20MHz / 4 wire standard

Supported Transducers

- Any geometry: Phased array, Linear, Convex, Generic (user defined)
- Connector pin-out defined for ZIF156 and ZIF260 TYCO connectors
- Frequency range: 500KHz to 12MHz
- Number of elements: 1 to 192
- Probe presets available for (available from Prosonic, Apex, and others)
 - L12-5L40N; Linear, 128 elements, 5-12MHz, 40mm
 - L12-5L40H; Linear, 192 elements, 5-12MHz, 40mm
 - P4-2L20S; Phased Array, 64 elements, 2-4MHz, 20mm
 - C7-3R50N; Convex, 128 elements, 3-7MHz, 50mm R

Electrical

- Medical external power brick 2 prong, 60W 100-240V AC
- Size of AC/DC PS: 5in x 2in x 1in
- System input: 15VDC $\pm 10\%$ / 4A max
- Power consumption: 30W - 45W (based on operating mode)
- Operating Temperature Range: 32 F to 122F ; 0C to 50C

Dimensions

- Size: 11.5in/30cm (W) x 6.5in/17cm (W) x 4.5in/12 (H)
- Weight: 7lb/3.2 kg